

College of Engineering
University of California, Berkeley
Spring 2016
Volume 9

Rising seas
Infrastructure reboot

Thermoelectrics
A new, old tech

Open airspace
Drone responsibility

BerkeleyENGINEER



LIFE WITH MACHINE

Robot relationships get real

The future of intelligence

Machine intelligence and robotics have made giant progress recently — with automated cars, flying machines and robotic manufacturing on the front pages of the popular press, seemingly every week. To learn more about the Deep Learning technology behind these artificial intelligence (A.I.) advances, *Rolling Stone* and the *Atlantic* came to some of Berkeley's most outstanding young roboticists, introducing readers to Pieter Abbeel's "robot nursery school," where robots learn as children do, by hand and by sight, and Anca Dragan's well-mannered autonomous vehicles, which back up politely to signal yielding to others at an intersection.

Designed to mimic the human brain's neural network, Deep Learning builds on research pioneered here at Berkeley in the 1980s. With the advent of massive computing power, it is now possible to bring such advanced machine learning to a number of new domains, including driving, computer vision and robotics.

At a Dean's Society event last December, a panel of A.I. researchers discussed the breadth of the work at the college. Cortera Neurotechnologies co-founder and new EECS faculty member Rikky Muller discussed how brain-machine interfaces can help people with neurological differences lead fuller lives. IEOR professor Ken Goldberg, who leads the CITRIS People and Robots Initiative, discussed advances in robotic surgery with alumnus Gary Guthart, CEO of Intuitive Surgical, makers of the minimally invasive da Vinci Surgical System. Computer science professor Stuart Russell, who co-wrote the seminal A.I. textbook with alum and fellow panelist Peter Norvig of Google, spoke about the evolution of machine intelligence and the need to build fundamental human values into machine learning. Stuart, who taught a class on that subject this past term, is also leading an international campaign to require safeguards in lethal autonomous weapons systems.

We face important questions about how robots will work with humans, how machine learning and A.I. can be integrated into societal systems and indeed, the workplace of the future. As part of our mission to serve society, we are well-poised at Berkeley to assess the potential complications associated with augmenting human cognitive capabilities, while at the same time addressing the economic, legal and social consequences of this emerging technology.

As always, I welcome your thoughts and ideas.



—S. Shankar Sastry

DEAN AND ROY W. CARLSON PROFESSOR OF ENGINEERING
DIRECTOR, BLUM CENTER FOR DEVELOPING ECONOMIES

With Deep Learning technology, A.I. is making a huge leap forward.

Georgia Institute of Technology engineering dean Gary S. May (M.S.'88, Ph.D.'91 EECS, 3rd from right), returned to campus in March to deliver the 2016 Kuh Lecture on broadening participation in STEM. The lecture was part of the daylong Berkeley Engineering Stars in Technology (BEST) workshop sponsored by the EECS department. This year, BEST brought attention to the accomplishments and challenges of African-American engineers.



in this issue

Berkeley **ENGINEER** SPRING 2016

2

GROW YOUR OWN
Smart fungi



4

MARSH ORGAN
Restoring tidal wetlands



14

THERMOELECTRICS
A new, old tech

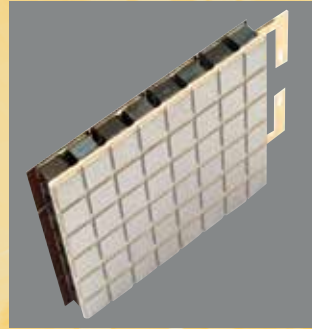

18

RESPONSIBLE ROBOTICS
Tools for drone operators



MORE >

2-5 UPFRONT

Comments
Learning to levitate
suitX
From waves to electricity
Election data Q+A

6-7 BREAKTHROUGHS

Let them see you sweat
Say cheese
Fingerprint scanner
Invisibility cloak
Cool composites
Making monolayers work

8-11 LIFE WITH MACHINE

Robot relationships get real

12-13 RISING SEAS

A new look at resilient infrastructure

20-26 ALUMNI NOTES

Spotlights
Farewell

> COVER PHOTO **NOAH BERGER**

DEAN
S. Shankar Sastry

ASSISTANT DEAN
COLLEGE RELATIONS
Melissa Nidever

EXECUTIVE EDITOR
Karen Rhodes

MANAGING EDITOR
Kap Stann

ASSOCIATE EDITOR
Daniel McGlynn

DESIGN
Alissar Rayes

CONTRIBUTORS
Denise Bui
Julianna Fleming
Thomas Walden Levy
Amy Marcott
Paul Preuss
Nate Seltenrich
Kristine Wong
Sarah Yang

Berkeley Engineer is published twice yearly to showcase the excellence of Berkeley Engineering faculty, alumni and students.

Published by: UC Berkeley College of Engineering, Office of Marketing & Communications, 312 McLaughlin Hall #1704, Berkeley, CA 94720-1704, phone: 510-643-6898, website: engineering.berkeley.edu/magazine

Reach editors: berkeleyengineer@berkeley.edu

Change of address? Send to: engineerupdates@berkeley.edu

Donate online: engineering.berkeley.edu/give, **or mail to:** Berkeley Engineering Fund, 308 McLaughlin Hall #1722, Berkeley, CA 94720-1722, phone: 510-642-2487

© 2016 Regents of the University of California / Not printed at state expense.

 Please recycle.
This magazine was produced from eco-responsible material.



Noah Berger

Reishi mushroom

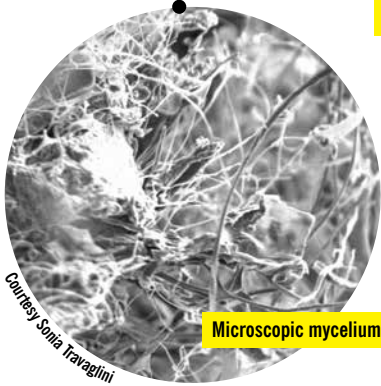

Microscopic mycelium

Courtesy Sonia Travaglini

“ I HAVE NEVER SEEN SUCH A LOW-COST, LOW-IMPACT MATERIAL. THAT’S WHAT CAUGHT MY ATTENTION, THE IDEA THAT IT IS COMPLETELY SUSTAINABLE, AND LITERALLY MUSHROOMS.”

— SONIA TRAVAGLINI | MYCOLOGY MATERIALS ENGINEER

MATERIALS

Grow your own

Mycelium, the sprawling, thready, root-like part of a fungus (the mushroom parts are fruiting bodies) are fast-growing and easily manipulated into shapes and forms. While several commercial applications for mycelium-based materials are already on the market, little is known about the material’s properties.

“Before now, people who used this material intuitively knew how strong it was,” says **Sonia Travaglini**, a mechanical engineering Ph.D. candidate, “but no one had done the research to say, ‘yes, you can pile so much weight on it before it will fail.’ So that’s what I’m researching — the material properties — particularly its strength, crushability, toughness and maximum use temperature.”

Mycelium’s strength comes from chitin, the structure the fungus builds to support

itself. This chitin, the same material that constitutes beetle shells, will digest a substrate, which could range from sawdust to coffee grounds. The result, if grown in a form, is a durable matrix that can be further worked or molded with tools.

Currently working out of Jacobs Hall, Travaglini is collaborating with Phillip Ross, the founder of a project called MycoWorks, a Silicon Valley-based design and engineering firm working to make mycology materials more accessible.

So far, the emerging applications for this ancient material range from packaging and building insulation to furniture and core material for veneered plywood. Life-cycle sustainability makes these materials economically attractive to certain industries. “What really surprised me about mycelium is that it can grow off waste,” Travaglini says.



COMMENTS

We received a number of emails and messages following the fall issue of Berkeley Engineer, particularly about the “Sophie’s super hand” story. A few people, who have hand differences like Sophie’s, contacted us asking to get involved with the project. One of the featured researchers, **Daniel Lim**, invited these readers to participate in the ongoing research.

“I too was born with nubbin fingers on my right hand, 75 years ago. Throughout my life, I have been able to do most activities done by people without this limitation. My career was in the computer field, and I have a deep interest in 3-D printing technology; before reading about Sophie’s super hand I wondered if I could ever make myself a 3-D printed prosthetic. I would love to work on making such a prosthetic and engage my young grandsons in this project.”
—Herold Martinez, via email

“A great story and great engineering effort!”
—Brian Choi, via YouTube

“I make hands like this for e-NABLE [enablingthefuture.org] — very rewarding work.”
—Jason Benson, via Facebook

“A left-handed super hand...WOW! Getting a grip and moving forward.”
—Charles Koenig, via Facebook

“Fantastic! Thank goodness for brilliant scientists like these!”
—Belinda Milford, via Facebook

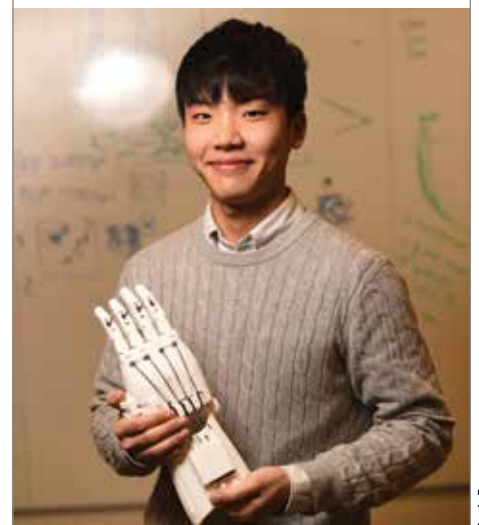

Noah Berger

Daniel Lim

HYPERLOOP

Learning to levitate

Before shooting their futuristic vehicle down a test track at high speeds for a design competition this summer, 40 Berkeley students must first make their Hyperloop pod levitate.

The world's Hyperloop fascination started back in 2012, when SpaceX founder Elon Musk let loose the futuristic vision of a mass transit system in which people board pressurized capsules to zing through reduced-pressure tubes on rails of air.

Last year, SpaceX hosted a competition for university students, and in January, the Berkeley team was invited to build a working prototype of their design. The team is working toward launching a pod on a test track in Hawthorne, California this August.

Berkeley Hyperloop (bLoop) team members have set up shop at the Richmond Field Station to build a pod that is not quite full size, but still substantial enough to carry a 100-pound test dummy. Third-year mechanical engineering student **Neelanjan Lahiri** says that their design puts safety first. "The higher you levitate, the more air you need, and you need to make sure that the braking is good," he says.

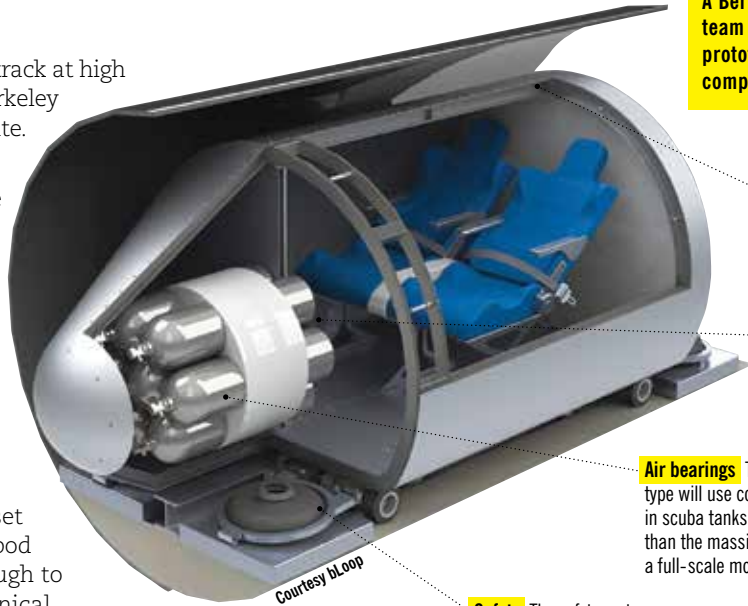

A Berkeley-based Hyperloop team is building a working prototype to test at a design competition in August.

Pod The team is building the pod at the Richmond Field Station with a weight target of under 2,000 pounds.

Signals and controls A working Hyperloop pod will need to communicate with stations and other pods.

Air bearings The scaled-down prototype will use compressed air stored in scuba tanks for levitation, rather than the massive air compressor that a full-scale model would require.

Safety The safety systems are based on designs already used in conventional mass transit systems, including BART.

ACCESSIBILITY

Affordable and lightweight suitX design honored

Earlier this spring, the startup company suitX won a Robotics for Good competition for their plan to adapt one of their exoskeleton designs to assist children with conditions such as cerebral palsy, spina bifida or spinal muscular atrophy.

Co-founded in 2013 by mechanical engineering professor **Homayoon Kazerooni** and four other researchers from Berkeley, and with roots in the Robotics and Human Engineering Lab, suitX builds motorized exoskeletons designed to be more affordable than the competition. Their current models cost about \$40,000, less than half the cost of others on the market.

Wearing suitX, the user's knees and hips are assisted by small motors housed in the joints of the exoskeleton frame; controls are embedded in handheld crutches, and a battery backpack provides power. Modular components are adaptable to different sizes and mobility needs.

The Robotics for Good competition was hosted by the United Arab Emirates. The competition began with 664 entries from 121 countries, with suitX winning the top honor and \$1 million prize.



“We can't really fix their disease. We can't fix their injury. But what it would do is postpone secondary injuries due to sitting. It gives a better quality of life.”

— HOMAYOON KAZEROONI | ME PROFESSOR, SUITX CO-FOUNDER | February 1 | *Technology Review*

ENVIRONMENT

Restoring tidal marshlands

A decade after Hurricane Katrina devastated New Orleans, **Madeline Foster-Martinez**, a civil and environmental engineering doctoral student and Louisiana native, is investigating how to use biosolids to make tidal wetlands less vulnerable to storm surges. Dredging spoils are currently used to shore up marshes, but they are largely sand. Biosolids — treated sewage sludge from wastewater treatment plants — could add necessary nutrients to strengthen marshlands and better protect coastal regions.

“Marshes are just incredible — not only do they clean out pollutants, but they also sequester carbon, attenuate storm surge and provide habitat and food,” she says. “They do it all.”



Daniel McGlynn

A two-tiered marsh organ reveals how tidal variations affect plant growth — the lower tier stays wetter longer.

Native cordgrass, which typically carpets a healthy marsh, allows researchers to compare the suitability of biosolids as a marsh-restoring additive.

Thick-walled, six-inch-diameter PVC tubes are packed with different materials for testing.

Control tubes are packed with local dredging spoils; the remaining tubes contain a mixture of biosolids added to the spoils.

Illustration courtesy Madeline Foster-Martinez

ENERGY

From waves to electricity

Reza Alam, an assistant professor of mechanical engineering, studies how mechanical devices might convert ocean waves into electricity. In 2012, visiting graduate student **Marcus Lehmann** joined Alam’s Theoretical and Applied Fluid Dynamics Lab. His designs for a working prototype helped spark Alam’s lab to begin building a machine to harness wave energy, which they call a Wave Carpet.

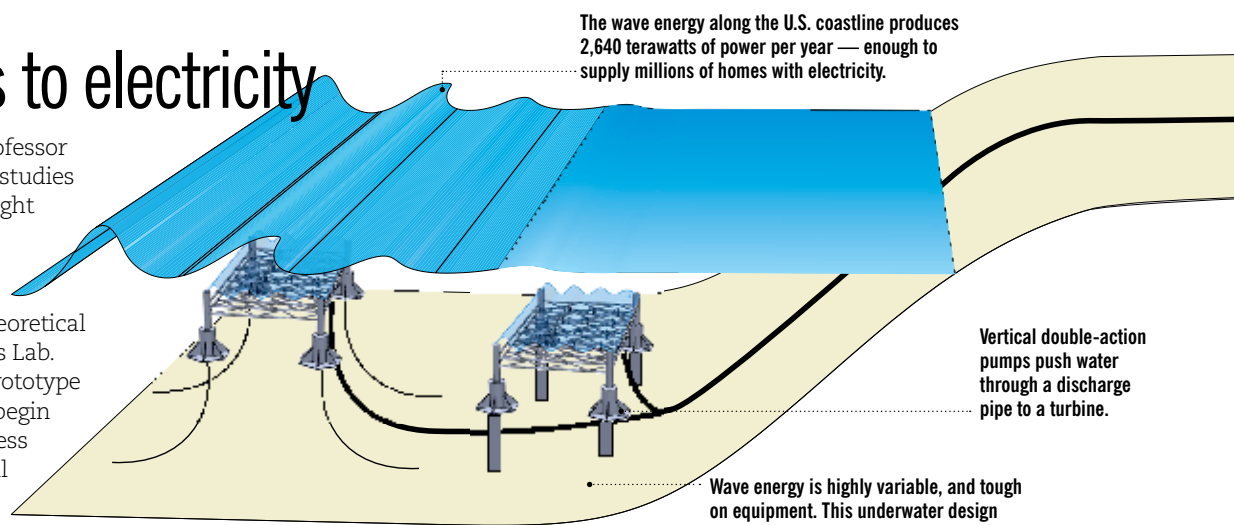

The wave energy along the U.S. coastline produces 2,640 terawatts of power per year — enough to supply millions of homes with electricity.

Vertical double-action pumps push water through a discharge pipe to a turbine.

Wave energy is highly variable, and tough on equipment. This underwater design shelters the pumps from potential damage.

Courtesy Marcus Lehmann

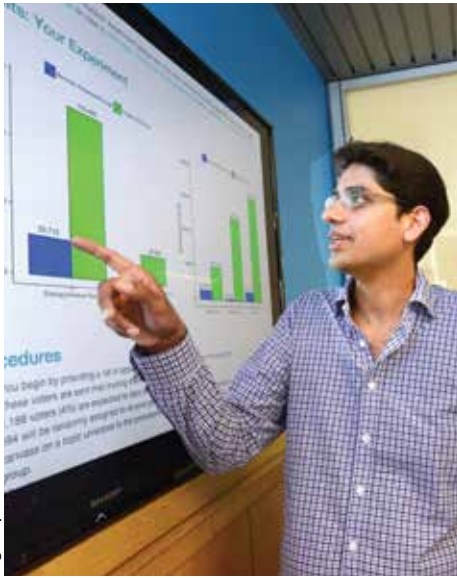

Peg Skorpinski

Jasjeet Sekhon is the chief scientist at the Fung Institute for Engineering Leadership. He holds faculty appointments in political science and statistics, and he is a senior fellow at the Berkeley Institute for Data Science. Sekhon's research applies computational and statistical analysis to massive datasets of granular information collected about people. In addition to using that data to study how persuasion works in elections, he also studies the effectiveness of digital advertising and personalized medicine.

Where do data and elections converge?

When and how often you vote is part of the public record. Where you live is part of the census data. With that information alone, politicians can make assumptions about you and how you will vote. The most boring version of this results in targeted mail, which most people have seen. But the use of data is becoming more sophisticated. It's not just a mailer anymore; now there might be an experiment embedded in it to try to figure out the right messaging a candidate should use. The cost of doing that kind of thing is coming down as data services and infrastructure become less expensive.

During the elections of 2012 and 2014, experiments were performed on 20 to 30 million potential voters, and that isn't even counting the online-only experiments. The largest experiments ever done on people are happening right now.

When did data become such an important part of political campaigning?

U.S. elections in particular, and certainly for the president, have been transformed. In 2000, the election was shockingly close. That made people think more about the small margins. In 2008, the Obama campaign had a large analytics team. They ran lots of experiments and randomized different appeals. They were able to collect individual data on people in battleground states. By 2012, the Obama campaign had gotten really good at this and became a huge machine.

How is the 2016 election shaping up to be different from previous elections?

Our data is good enough that we can make predictions with a high level of probability when the elections are close and stable. But in this election, with a

wild-card candidate like Donald Trump, the normal predictive models may not be accurate anymore.

What's next?

Getting people to vote is one thing, but changing their mind about candidates or issues — persuasion — that's a much messier problem. How do you know if a campaign ad or a piece of direct mail actually changed a voter's mind? Probably by 2020, we will have addressable TV, which means TV ads that can be targeted to an individual viewer, much like how Internet ads work. That will not only change how elections operate, but it will be a huge change for advertising. We'll be able to better understand how effective ads are.

Where else do these lessons apply?

The commonality between election data and other forms of human data is that it is very granular and it is about the way people behave, whether it's an Internet ad or the effectiveness of a new drug or a political campaign. We haven't been here before, and there's still a lot we don't really know.

Shore-based turbine converts mechanical energy to electricity.

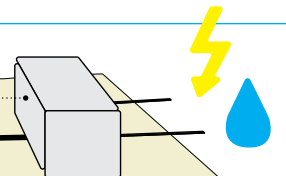

PROBLEM There is enough energy in the waves hitting the nation's coastline to power millions of homes per year. But harnessing that energy is complicated: wave heights and frequencies can vary wildly over time and from one shoreline to another, seawater is highly corrosive, and storms can turn reliable and predictable waves into battering rams.

SOLUTION The Wave Carpet is a seafloor-based device that absorbs ocean wave energy and converts it into mechanical energy that can generate electricity. When activated by waves, the device's highly flexible membrane drives a series of vertical double-action pumps to pressurize and push seawater through a discharge pipe to power a shore-based turbine.

RESULT In 2014, with help from Alam, Lehmann led the Wave Carpet team's effort to land a two-year \$500,000 grant from Cyclotron Road, the Berkeley Lab's clean energy incubator, to support continued work on its wave energy converter. The team filed for a U.S. patent in 2012. This year, Lehmann says the team plans to put a demonstration device in the sea.

SENSORS

Let them see you sweat



Berkeley engineers are going to make you sweat — and it's all in the name of science. Researchers have devised a flexible sensor system that can measure metabolites and electrolytes in sweat, calibrate the data based upon skin temperature and then sync the results in real time to a smartphone. While health monitors have exploded onto the consumer electronics scene over the past decade, researchers say this device is the first fully integrated electronic system that can provide continuous, non-invasive monitoring of multiple biochemicals in sweat. The prototype, developed by electrical engineering and computer sciences professor **Ali Javey** and his team, including postdoctoral fellows **Wei Gao** and **Sam Emaminejad** and Ph.D. student **Hnin Y.Y. Nyein**, packs five sensors onto a flexible circuit board. The sensors measure the metabolites glucose and lactate and the electrolytes sodium and potassium, along with skin temperature. This advance opens doors to wearable devices that alert users to health problems such as fatigue, dehydration and dangerously high body temperatures.

DATA MINING

Say cheese

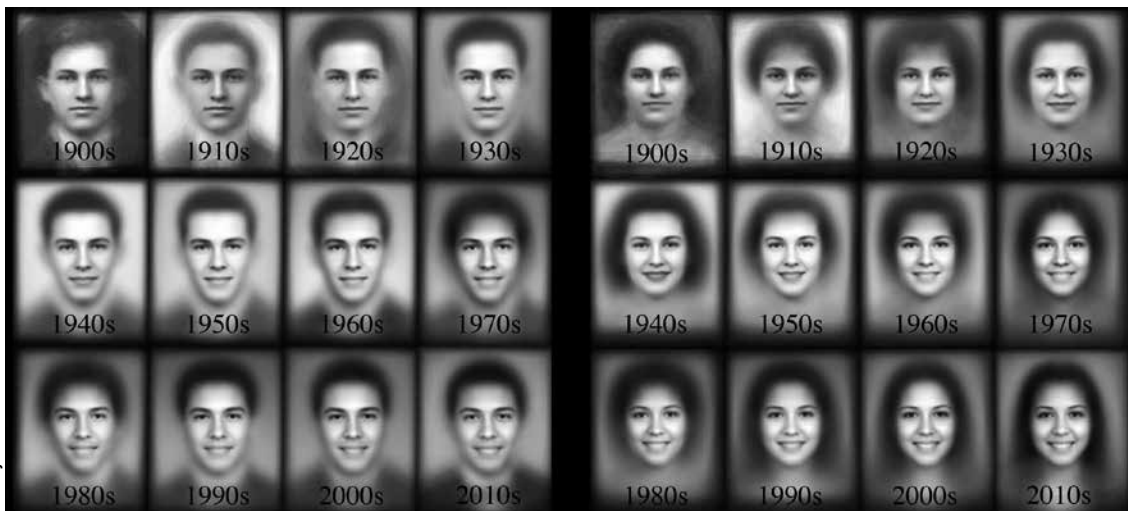

Since 1839, when the daguerreotype camera was first introduced, photographs have documented our history and culture. But it has been challenging for historians to make use of this vast set of visual information using data-mining techniques. Now, computer science Ph.D. student **Shiry Ginosar** and her team have demonstrated a groundbreaking approach to analyzing large collections of photos. Working with American high school yearbook photographs from 1905 – 2013, the researchers used a dataset of over 37,900 images from more than 800 yearbooks across 26 states. After grouping the pictures by decade and gender, they superimposed the photos to create an average face for each timespan. They also used machine learning techniques to identify distinct clusters of images, as well as deep learning techniques to predict the year in which each image was taken. Their results show the changes over the last century in hairstyles, clothing and even smiles. Previously, researchers would have had to invest significant hours and labor to manually analyze the photos, but the techniques pioneered by the team required minimal human effort. The scientists believe these methodologies can radically change the way in which visual media are used in future humanities research.



SECURITY

FINGERPRINT SCANNER: A new ultrasonic sensor raises the security standard of fingerprint sensor technology currently used on smartphones and other devices. Developed by the Berkeley Sensor & Actuator Center, co-directed by **Bernhard Boser**, professor of electrical engineering and computer sciences, it makes the image of the fingerprint three-dimensional, eliminating the risk of counterfeited two-dimensional images. The new sensor pictures the ridges and valleys of the fingerprint's surface, as well as the tissue beneath.

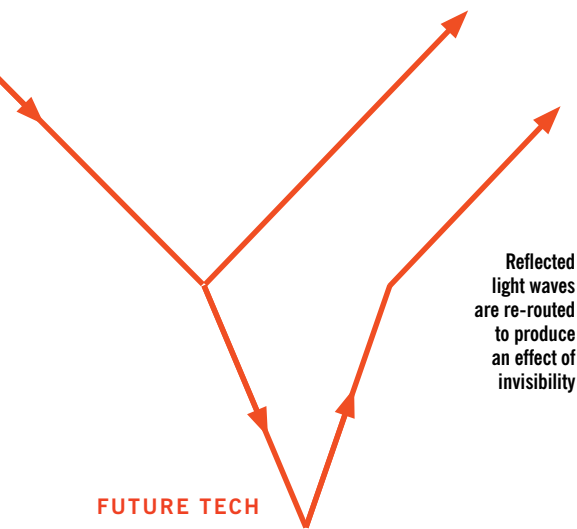

FUTURE TECH

Invisibility cloak

Before long, invisibility cloaks may be bounding off the pages of *Harry Potter* into real life. In the latest breakthrough for this futuristic technology, mechanical engineering professor **Xiang Zhang** and a team of researchers have designed an invisibility cloak that can be wrapped around a three-dimensional object of arbitrary shape and conceal it from detection with visible light.

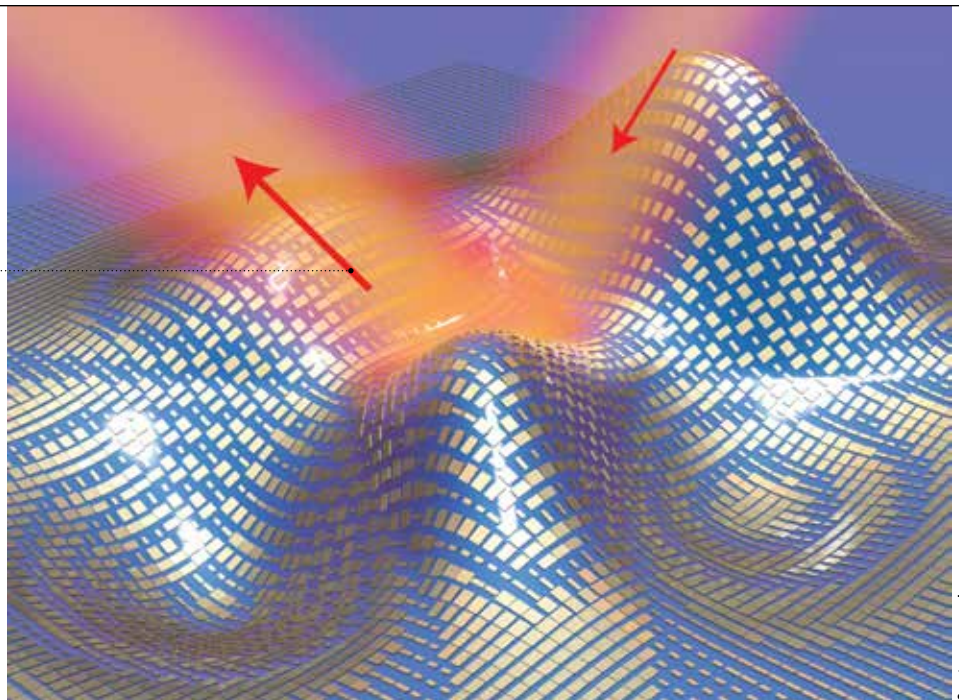

Courtesy researchers

Just 80 nanometers thick, the microscopic “skin cloak” was made using gold nano-antennas, which re-route reflected light waves around the object to hide it from view. Previous versions of this technology

had bulky structures that were difficult to scale up. “Our ultra-thin cloak now looks like a coat,” says Zhang. “It is easy to design and implement, and is potentially scalable for hiding macroscopic objects.”

MATERIALS

Cool composites

Like polar bears and snowmen, some things perform at their best in the cold, including CrMnFeCoNi, a metallic alloy made of chromium, manganese, iron, cobalt and nickel. Although it’s incredibly tough and strong at room temperature, the alloy actually becomes tougher and stronger the colder it gets — unlike most materials. Now, materials science professor **Robert Ritchie** and a team of scientists have identified the mechanisms that make it one of the toughest metallic alloys at any temperature. Using transmission electron microscopy, the researchers studied the alloy at nanoscale as it was subjected to strain. The resulting images showed how several phenomena work together to prevent damage from spreading, including structures that develop across cracks like bridges to prevent them from growing wider. Commonly seen in composites and ceramics, this bridging mechanism is unusual in unreinforced metals. Future applications may include cryogenics as well as research to design stronger, tougher metallic materials.



Photoluminescence of MoS₂ monolayer: before (left) and after superacid treatment

MAKING MONOLAYERS WORK: An emerging class of atomically thin materials known as monolayer semiconductors has generated a great deal of buzz in the world of materials science. Monolayers hold promise in the development of transparent LED displays, ultra-high efficiency solar cells, photo detectors and nanoscale transistors. Their downside? The films are notoriously riddled with defects, killing their performance. But Berkeley engineers have found a simple way to fix these defects by dipping molybdenum disulfide, or MoS₂, into an organic superacid called bistriflimide, or TFSI. The treatment led to a dramatic 100-fold increase in the material’s photoluminescence quantum yield, a ratio describing the amount of light generated by the material versus the amount of energy put in — the greater the emission of light, the higher the quantum yield and the better the material quality. Their findings open the door to the practical application of monolayer materials in optoelectronic devices and high-performance transistors. Berkeley Engineering professors **Ali Javey**, **Eli Yablonovitch** and **Xiang Zhang** worked on the study with Ph.D. student **Matin Amani**, visiting Ph.D. student **Der-Hsien Lien** and postdoctoral fellow **Daisuke Kiriya**, as well as researchers from National Taiwan University, the University of Texas at Dallas and the U.S. Army Research Laboratory in Maryland.

HOW DO I FIND OUT MORE?

Find links to source articles, news details and expanded coverage at engineering.berkeley.edu/magazine.

LIFE WITH MACHINE

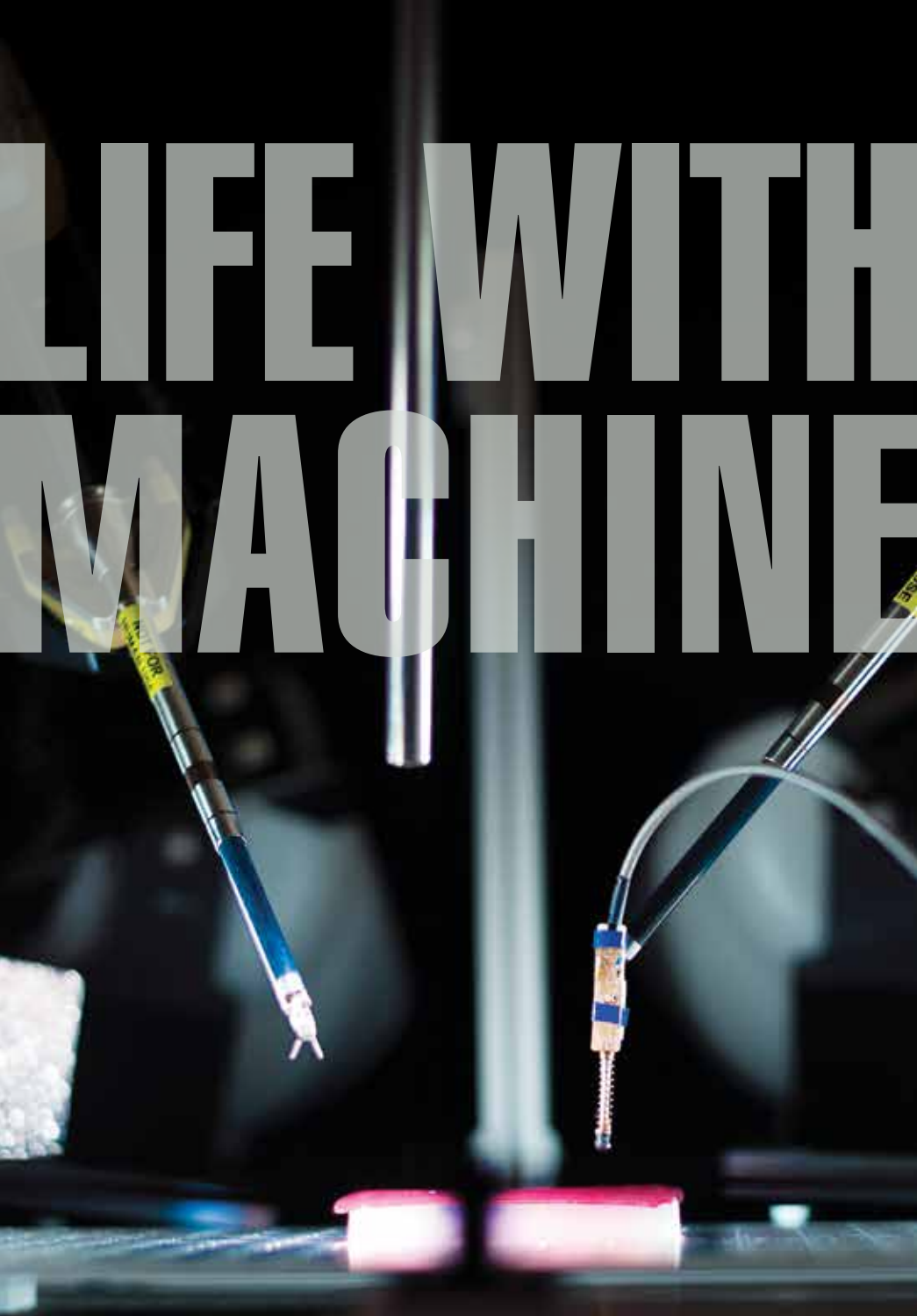

ROBOT RELATIONSHIPS GET REAL

STORY BY PAUL PREUSS • PHOTOS BY NOAH BERGER

Berkeley's renowned programs in artificial intelligence and robotics involve scores of professors in the College of Engineering. Not one of them is typical — as here, where three quite different researchers discuss technologies that are bringing machines and humans into closer relationships. Rikky Muller works at the boundary where sensitive machines and human brains make physical contact. Ken Goldberg trains robots to work independently and act competently in the world around them. Anca Dragan coaches robots and humans to understand one another's intentions. Their aim is to create machines with the intelligence to better serve and work with human beings.

//////////MACHINES THAT LISTEN//////////

Imagine, floating on the surface of your brain, there's a fleck of polymer the diameter of a pencil eraser and as thin as Saran Wrap; it carries an array of micro-electrodes that listen to signals from your motor cortex. The neurons in that region, at the top of your head, fire when you walk around, pick up a glass of water, type a text message or move in other ways.

The neuronal signals are digitized and sent from your head to a computer by a tiny loop antenna; the same antenna transmits data and receives power for the implant, rendering internal batteries and skull-piercing wires unnecessary. The whole brain-machine interface resides on a chip safely sealed inside your head.

"Signals recorded from the motor cortex can be used to control a multitude of external devices," says Rikky Muller, an assistant professor of electrical engineering and computer sciences (EECS) since January 2016. "That includes robotic prosthetic arms: if you're paralyzed, it's a way to bypass any 'open circuits' in your body and connect signals directly from your brain."

With bachelor's and master's degrees in electrical engineering from MIT, Muller came to Berkeley in 2007 to pursue her Ph.D., concentrating on integrated circuit design and neuroengineering. Intent on developing a new kind of neural implant, she says, "I took a very clinical focus on how we can make something that really lasts a long time and is safe inside the brain."

Muller's close collaboration with her advisor, EECS professor Jan Rabaey, and others including EECS associate professor Michel Maharbiz, led to the design of an ultra-small, minimally invasive wireless implant. Its sensors are offered to researchers as the first product of Cortera Neurotechnologies, which the inventors founded in 2013. Muller was Cortera's first CEO and later its chief technology officer.

Cortera participated in one of the first grants from President Obama's 2013 BRAIN initiative, charged with developing an implant that not only records but actually stimulates the brain. The goal is to treat serious neuropsychiatric disorders where treatment has been elusive, including post-traumatic stress disorder and major depression. The project comes with profound technical challenges.

For one, deep-brain stimulating electrodes require much more power than

recording electrodes. “You have to put a lot of thought into how you power these systems and design for efficiency,” says Muller. The objective is to adjust the delicate balance of sensitive recording and intrusive stimulation automatically and individually, for each patient.

Muller is nothing if not determined. Whether the recipient is quadriplegic or suffering with PTSD, she says, “What’s important to me is to get the technology into the hands of patients — to give options to people who currently don’t have any options.”

//////////MACHINES THAT TOUCH//////////

Ken Goldberg, a professor of industrial engineering and operations research (IEOR), seeks to extend close cooperation between humans and machines to the widest possible contexts.

A year ago, for the Berkeley-based Center for Information Technology Research in the Interest of Society (CITRIS), Goldberg launched the “People and Robots” initiative (CPAR), partly in response to the much-discussed *singularity* — the fear that runaway machine intelligence could threaten the human race. Countering with the concept of *multiplicity*, CPAR brings together diverse groups of robots, humans and algorithms to solve problems efficiently through collaborative learning.

Goldberg traces his enthusiasm for robots all the way back to the TV show *Lost in Space*. He studied economics and electrical engineering at the University of Pennsylvania, then completed his Ph.D. in robotics at Carnegie Mellon. He joined the Berkeley faculty in 1995 and has appointments in the School of Information, new media, art practice (independently, he’s a recognized artist) and the department of radiation oncology at UC San Francisco.

Medical robotics is a leading example of machines collaborating intimately with humans. Since 2000, the da Vinci Surgical System, a robotic device guided by surgeons working from nearby consoles, and made by Sunnyvale-based Intuitive Surgical, has performed three million minimally invasive laparoscopic surgeries.

A da Vinci system has two or more articulated arms ending in slender probes. One is mounted with a tiny camera; others wield forceps, needles, cauterizers or other instruments. The surgeon watches high-definition video from the camera



Rikky Muller

ASSISTANT PROFESSOR // EECS



Ken Goldberg

PROFESSOR // IEOR

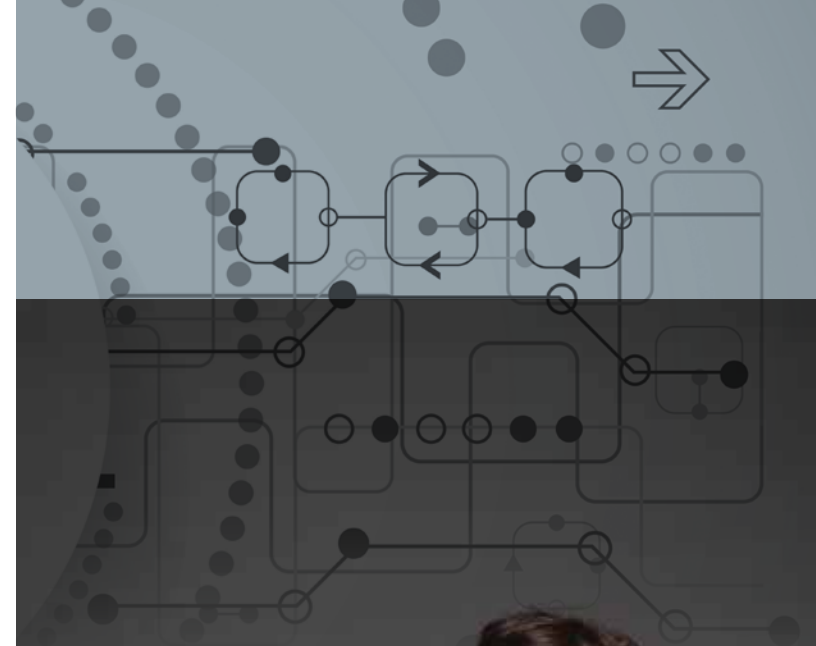

Anca Dragan

ASSISTANT PROFESSOR // EECS

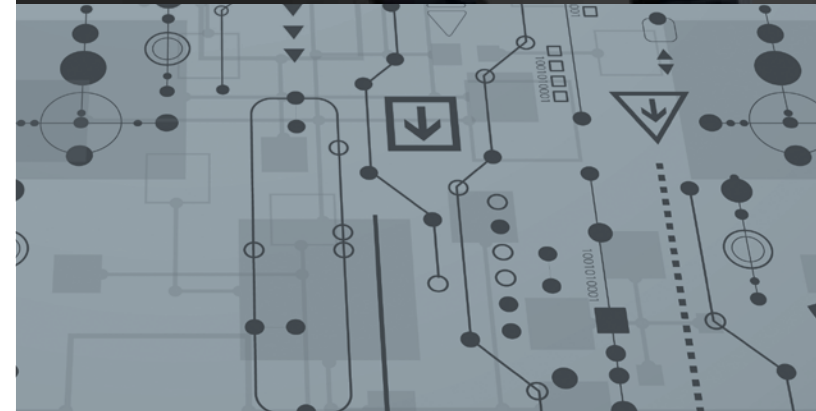
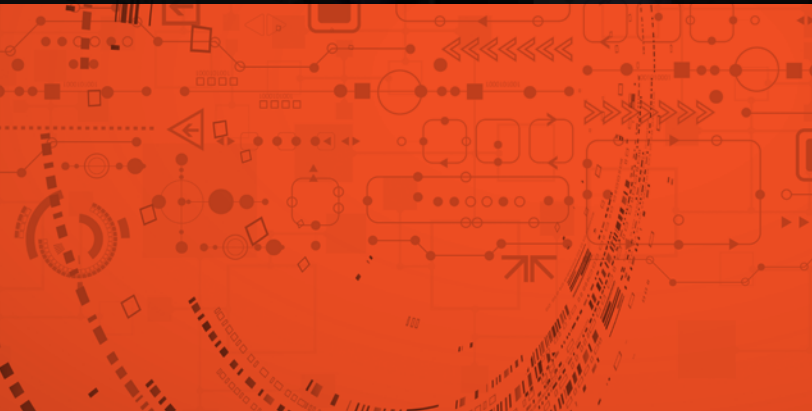

The newly reconstituted Berkeley Artificial Intelligence Research Lab builds upon A.I. research pioneered at the college since the 1980s.

WEB EXTRA > bair.berkeley.edu

while manipulating handles that cause the instruments to reproduce the movement of wrists, hands and fingers.

In 2014, Intuitive Surgical, which is led by CEO Gary Guthart, a Berkeley engineering physics alumnus, made a first-generation da Vinci research kit available to Goldberg and EECS professor Pieter Abbeel. Later that year, Goldberg and Abbeel founded the Center for Automation and Learning for Medical Robots (Cal-MR), which aims to extend the ability of both humans and robots to cooperate in performing new tasks and learning from one another.

Although Goldberg wants medical robots to have some ability to act on their own, he's firm that "we're trying to assist surgeons, not replace them." He targets tedious tasks that robots could do as well as surgeons, such as debridement — the removal of dead tissue and other debris. "It can take hours," says Goldberg, "and it's not using the best skills of the surgeon."

To teach the robots what to do, Goldberg and Abbeel had them learn from demonstration videos by expert surgeons. Robots then autonomously removed debris from lifelike plastic models of tissue called phantoms. On early tests, the robots performed slower than surgeons but with equal dexterity.

Dexterity is essential for many robots now in the planning stage, such as a de-cluttering robot that simplifies housework or makes a home safer for the elderly by picking up what's dropped on the floor.

"Humans can pick up a wine glass or a salt shaker easily, because we have evolved complex manipulators," says Goldberg. "When a robot tries to do that, the table is soon littered and everything is on the floor." He and his students, working with colleagues at Google, are developing Dex-Net, the Dexterity Network, intended to link numerous robots together with the computing power of the cloud. By using the cloud's vast, constantly updated storage for 3-D models, Dex-Net will identify robust grasps for hundreds of thousands of objects.

For most, the idea of robots working with people conjures visions of humanoid machines. But in reality, helping robots will probably look more ordinary. Goldberg says, "For systems that combine the best of what humans can do with the best of what robots can do, it's unlikely the robots of the future will look anything like a human."

////////////////MACHINES THAT CONVERSE //////////////////

Still, when it comes to anthropomorphizing robots, "We can't help it!" says Anca Dragan. Happily, that human tendency plays a significant role in her research. An assistant professor in EECS, Dragan came to Berkeley last fall from Carnegie Mellon with a Ph.D. in robotics and human-robot interaction (HRI).

Dragan cites the robot character BB-8 in the blockbuster *Star Wars: The Force Awakens*: "I loved the interaction between BB-8 and the human characters," she says. "Its shape is just a sphere and a hemisphere, yet it's incredibly expressive. You can't help but read into its movements what it's 'thinking' and what it's about to do." BB-8's internal states are apparent to the humans, and — as Dragan's work shows — that kind of understanding is essential when people communicate with nonfictional robots.

Yet robot-human interaction didn't top the list of Dragan's interests when she started at Carnegie Mellon. At first, she focused on robot manipulation. In 2010, she and her colleagues demonstrated their work by having their robot pick up and move bottled drinks — over 490 of them, with better than 90 percent success. "Then we had to do something with the bottles, so we wrote a last-minute hack for the robot to hand them out to people. Some failures were so interesting they eventually led me to pursue human-robot interaction for my Ph.D."

Of 150 attempted hand-offs to those passers-by who were unfamiliar with robots, just seven were successful. "Over and over the robot would say, 'Please take the drink,' and wait for the person to reach over and take the drink. Instead they'd just stand there. They didn't know what they were supposed to do."

Intrigued, Dragan's lab at CMU reached out to HRI expert Maya Cakmak, who suggested spatial-temporal contrast: the robot should pick up the drink one way, then emphatically hold it out to communicate the intention to give it away.

Dragan was reminded of Walt Disney's principles of animation, which include exaggeration — like when a cartoon character's eyes bug out in surprise.

With that one change, she says, "People understood. Like magic, a subtle difference made everything work." Dragan then made it her goal to enable robots to devise such strategies by themselves, needing no designers to think them up.

Enabling better interaction is the traditional focus of HRI. Traditional robotics, on the other hand, emphasizes autonomy, concentrating more on function and less on interaction. Dragan aims to bridge this gap. "A robot must account for the effect it has on people, much like it accounts for the effect it has on the physical world. How people perceive the robot's plan in turn affects what the robot does."

Short of a brain-machine interface like that designed by Rikky Muller, robots must also be able to clearly express their own capabilities to human collaborators. These challenges are at the core of much current research.

For example, autonomous cars are currently designed with protective passivity; in 2015 a Google robot car was pulled over for driving so slowly it impeded traffic. Recently, Dragan has shown that autonomous cars could potentially increase safety and performance by assertive moves that signal intent — like speeding up to change lanes or backing away from an intersection to yield the right of way.

Dragan says, "If we want robots to go out into the world, then our planning and learning algorithms have to reason over not just the physical space, but the human space as well." From an HRI standpoint, she says, "We are starting to see that just designing interactions specific to a task is not enough. We need both, where we have algorithms that think about functional goals but also about interactions with humans."

BB-8 achieved that ideal a long time ago, in a galaxy far, far away. Smart machines here and now are steadily catching up. ■

Rising seas

A NEW LOOK AT RESILIENT INFRASTRUCTURE

A team of researchers is studying the impacts that sea-level rise will have on the Bay Area.

TEXT BY KRISTINE WONG • GRAPHIC BY ALEXEY POZDNUKHOV

We know that our changing climate will bring rising sea levels to the Bay Area. But do we know how to handle it? Mark Stacey, professor of civil and environmental engineering, has assembled a cross-disciplinary team to find out. The research is part of a National Science Foundation-sponsored initiative examining critical infrastructure resiliency.

“For several years, many have held the belief that the biggest barrier to solving environmental problems lies more on the social side than in the technology or the engineering,” Stacey says. “We’re trying to do a cross-disciplinary analysis.”

Stacey and his collaborators will collect data to build state-of-the-art hydrological models that will look at local and regional impacts of sea-level rise and storm events that result in coastal flooding.

Part of the research will identify potential traffic snarls caused by rising seas and suggest alternatives to future-proof infrastructure that is already strained. The transportation system’s interactions will also be used to shed light on the reactions of the various governmental agencies.

The ultimate goal of the research is to examine how city, regional, state and federal government agencies interact during a time of prolonged environmental

stress and find the places where officials and agencies can improve coordinated management of infrastructure and resources.

“We want to quantify the way overlapping jurisdictions engage in piecemeal decision-making and show that in regard to coastal flooding and sea-level rise, the structures of governance systems are mismatched with physical infrastructure — like levees and seawalls and the transportation system,” Stacey says.

Stacey is working with an interdisciplinary team on the research. He is joined by CEE colleague Alexey Pozdnukhov, an urban systems data analytics specialist; Samer Madanat, a former Berkeley transportation professor who is now dean of engineering at NYU in Abu Dhabi; Mark Lubell, a UC Davis political science professor who studies human cooperation in environmental policy; and oceanographer Li Erikson and geologist Patrick Barnard of the U.S. Geological Survey (USGS).

In the first phase of the four-year grant, Stacey is conducting data modeling to determine how sea-level rise, tides and storms will affect regional coastal flooding, while Erikson and Barnard make 100-year flood predictions using a USGS

tool. Pozdnukhov is using forecasts for regional sea-level rise and flooding to construct models showing the impacts to the traffic system.

Starting this summer, Lubell will survey a range of governing authorities along the shoreline to determine how decisions affecting coastal flooding policy are made.

Then, using the compiled research data, Madanat will come up with an ideal configuration of the Bay Area transportation system. “He’ll look at the traffic disruptions created in the future and figure out how to best invest in the system to minimize travel cost and travel time,” Stacey says. Madanat’s results will be presented as a series of recommendations on whether to invest more or less in specific infrastructure at the local level.

Over the next four years, while building the technical models and analysis, the team will collaborate with the Climate Readiness Institute, an organization founded at Berkeley that brings together policymakers and industry leaders in discussion with Bay Area climate scientists.

“We’re approaching this as a partnership with the managers and actors who make real decisions about how to prepare for and adapt to rising seas,” Stacey says.



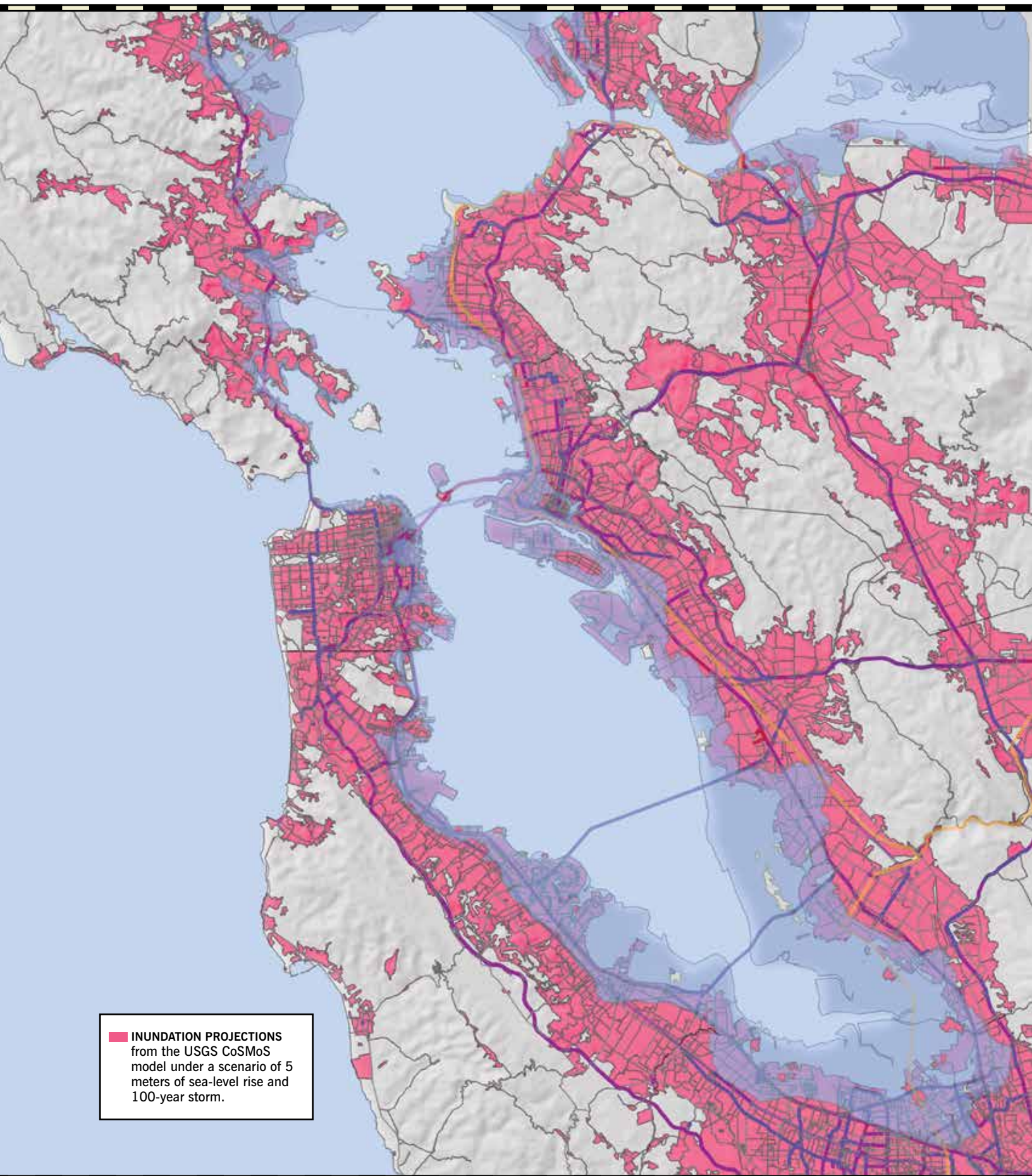

■ INUNDATION PROJECTIONS
from the USGS CoSMoS
model under a scenario of 5
meters of sea-level rise and
100-year storm.



THERMOELECTRICS: A NEW, OLD TECH



STORY BY NATE SELTENRICH
PHOTOS COURTESY ALPHABET ENERGY

A sprawling business park, near a patchwork of former salt ponds on the Hayward shoreline, houses more than its share of biotech and energy startups bent on changing the world. Tucked inside these nondescript boxes are companies making innovative batteries to store power from solar and wind farms, ingestible sensors called smart pills to help patients monitor medication intake and, at the offices of Berkeley-born Alphabet Energy, devices to convert wasted exhaust heat into clean, renewable power.

As physicist Thomas Seebeck discovered in 1821, certain materials that efficiently conduct electricity but not heat can transform any temperature differential into voltage by exploiting the flow of electrons from a warmer area to a cooler one. Engineers, inventors and entrepreneurs have tried to capitalize on the phenomenon ever since, using thermoelectrics to power radios, refrigerators, pacemakers and spacecraft. Others have attempted to turn waste heat from engines and industrial sources into electricity on a larger scale, but with limited success due to the low efficiency and high cost of thermoelectric devices.

Until now, that is. Seven-year-old Alphabet Energy is producing the most efficient thermoelectric devices ever made for waste-heat recovery, using abundant, cheap and scalable materials. CEO Matt Scullin, who founded Alphabet as a materials science graduate student at Berkeley in 2009, is working toward creating and cornering a new thermoelectrics industry by harnessing a vast resource: combustion exhaust heat from cars, trucks and power plants.

To illustrate the potential size of the thermoelectrics market, Scullin offers a back-of-the-napkin calculation. On average, two-thirds of all energy produced is lost as heat. With global annual energy consumption around 104,000 terawatt hours (about 33 percent of the total energy produced), it follows that 208,000 terawatt-hours are lost as heat in the process. If thermoelectrics could recover a conservative 5 percent of that, at the going rate of 10 cents per kilowatt-hour, that's a waste stream theoretically worth \$1 trillion per year.

"Waste heat is everywhere," Scullin says. "It is an absolutely huge opportunity."

But there's a greater good behind it all, too. By improving the efficiency of generators and engines while potentially displacing large amounts of energy produced by carbon-emitting sources, Alphabet's technology could be a boon for climate-change mitigation. According to

estimates using government data by the industry group Heat Is Power (where Scullin is on the board of directors), waste-heat recovery at existing U.S. oil, gas and manufacturing plants alone could save enough energy to power 11.4 million homes a year.



Scullin first started thinking about waste heat and thermoelectrics in 2005, while pursuing his Ph.D. dissertation under co-adviser Arun Majumdar, then a professor of mechanical engineering at Berkeley. "He kind of turned me on to the idea of waste-heat recovery," Scullin says of Majumdar. "Waste heat to me from the get-go was really, really interesting just because of the sheer size of the opportunity. I recognized that if we could just take a small fraction of this waste heat it could make a huge impact, but I was confused as to why this wasn't being done already."

Scullin found that existing approaches to large-scale waste-heat recovery were too complex and too costly. The solution, he came to believe, lies in simpler thermoelectric devices, particularly if they could be designed around cheap, abundant materials. Through a larger Department of Energy (DOE)-funded effort at Berkeley to develop thermoelectric generators for use in vehicles, he began studying a class of materials known as complex oxides — but eventually encountered an even better idea: using silicon nanowires to potentially quadruple the efficiency of other known thermoelectrics.

Scullin completed his dissertation, then promptly scuttled the technology he'd been studying in favor of taking a silicon nanowire product to market. "I love to tinker, I love to mess around with things," Scullin says in retrospect. "It's probably one of the main reasons I founded Alphabet."

Majumdar, who went on to direct the Advanced Research Projects Agency at the DOE and currently teaches at Stanford, says Scullin's timing was perfect. "When

we actually discovered that silicon was great and showed all these amazing properties, he was on a parallel project. He was watching all that happen.”

Scullin co-founded Alphabet in 2009 with Peidong Yang, materials science and chemistry professor and faculty scientist at Berkeley Lab — and a partner in the DOE thermoelectrics project — after the pair licensed a patent from Berkeley Lab and the university’s intellectual property office. Yang, whose research group led the development of the silicon nanowire technology starting around 2002, was named a MacArthur Fellow last fall for his work with semiconductor nanowires and nanowire photonics. He currently sits on Alphabet’s scientific advisory board.

In 2014, with silicon nanowire technology still in development, Scullin and Alphabet licensed another promising new thermoelectric, this time from the University of Michigan. Based on an affordable and readily available mineral called tetrahedrite, it offered impressive efficiency: not as good as silicon nanowires but still better than anything else available.

Within a year, Alphabet had shipped its first products.

The PowerCard, which resembles a tortilla chip-size solar panel, is Alphabet’s most basic thermoelectric device for

turning waste heat into electricity. As with all Alphabet technology, its preferred heat source is vehicle and generator exhaust at 300 to 600 degrees Celsius (572 to 1112 degrees Fahrenheit). A single PowerCard made with tetrahedrite can generate up to 9.2 watts of power simply by being exposed to pressurized hot air: no moving parts or emissions required.

The tiny cards can be sold individually, but they’re also at the heart of Alphabet’s fully enclosed, drop-in thermoelectric generator. The PowerModule, which measures 20 inches long, 24 inches wide and three inches thick — about the size of an extra-large pizza box — contains from a few dozen to more than 100 PowerCards, depending on whether the modules are destined for industrial use in generators or for vehicle use.

Commercial application in vehicles is the holy grail for thermoelectrics, Scullin says. The PowerModule can be inserted directly into a vehicle’s exhaust system: hot air goes in one end and out the other, just as with a muffler or catalytic converter, while it silently converts the energy in the waste heat into usable electricity, which is in turn fed back into the vehicle, offering a mileage improvement of up to 5 percent.

Another challenge is navigating the auto industry itself, which isn’t exactly known for turning on a dime. But the company has already made inroads by teaming with a U.S. manufacturer of exhaust systems to explore automotive applications, and last year it signed the first-ever commercial deal for thermoelectric waste-heat recovery with a global automobile manufacturer, which has yet to officially announce the deal. Scullin is hopeful that the PowerModule could find its way into production vehicles “relatively quickly.”

The task ahead for Alphabet comes down to the bottom line, says Majumdar. “The technology has to be at a scale where it can produce electricity at a lower cost than the retail cost of electricity. If someone can do that in a cost-effective way, it’s a big deal.”

Scullin believes Alphabet’s thermoelectrics already offer an attractive return on investment in both industrial and automotive applications. “The economics of this can be very, very good to the customer. They are already as good as solar, and we see how much solar has been adopted,” he says. “Waste heat is one of the greatest untapped resources that we have.” 

THERMOELECTRICS TIMELINE

Courtesy of Alphabet Energy



1821

Thomas Seebeck discovers that a circuit made from two dissimilar materials produced a voltage when their junctions were at different temperatures. It is later found that a voltage is induced in any material in a temperature gradient, known as the “Seebeck effect.”

1928

Abram F. Ioffe launches the modern theory of semiconductor physics to describe thermoelectric energy conversion, opening up the understanding of how to engineer thermoelectric materials — as well as providing the basis for understanding the physics of transistors and microelectronics.



1930

The Rodina 52 Russian radio was the first publicized radio powered by thermoelectrics. The radio was heated by a kerosene lamp, widely used during this time period.



1993

Lyndon Hicks and Mildred Dresselhaus publish a theory paper indicating that nanotechnology may offer significant advances in the efficiency of thermoelectric materials, ushering in the modern era of thermoelectrics.



1998

Seiko introduces the Thermic watch, the first watch powered from body heat, which uses a Bismuth Telluride (Bi_2Te_3) thermoelectric generator.



2001

RTI International reveals the first significant breakthrough in thermoelectric material efficiency in 40 years by using nanoscale materials.

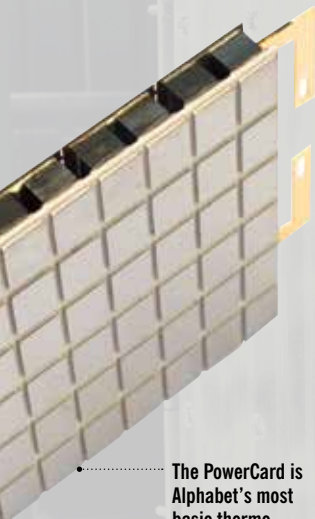

The PowerCard is Alphabet's most basic thermoelectric device for turning waste heat into electricity.

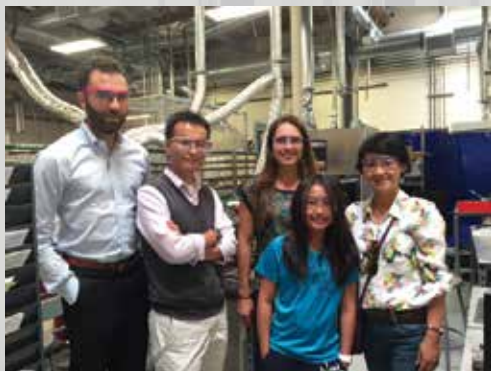

Top left: Co-founder, scientific advisor and MacArthur Fellow Peidong Yang with his family touring the Alphabet Energy plant with CEO Matt Scullin and engineer Lindsay Miller (Ph.D.'12 ME).

Above: Matt Scullin and Alphabet Energy engineer Jordan Chase measure the PowerCard's properties in the company's Hayward lab.

Left: Alphabet's products are modular and capable of working across scale to capture waste heat and convert it to electricity. The E1 system is packed inside a standard ocean freight-sized container and designed for heavy manufacturing and industry. The 1.6 x 1.9 inch PowerCard is designed for smaller applications.

1947

Maria Telkes constructs the first thermoelectric power generator with a milestone efficiency of 5 percent.



1959

Westinghouse unveils a home refrigerator based on Bismuth Telluride (Bi_2Te_3) Peltier thermoelectrics. While commercially unsuccessful, later thermoelectric refrigerators would become popular as wine coolers.

1970

The first cardiac pacemaker powered by a miniature radioisotope thermoelectric generator, made by Medtronic, is implanted into a human in France.



1977

NASA launches Voyagers 1 and 2, each powered by MHW-RTG3 Silicon Germanium (SiGe) thermoelectric generators.

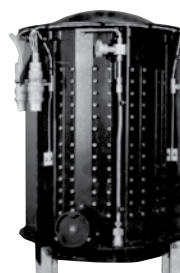

2004

The US Department of Energy (DOE), along with General Motors, BMW, Caterpillar and others, funds a program for automotive thermoelectric generators that drives much of the thermoelectric generator research for the next several years. DOE also funds a program on new thermoelectric materials, led by Arun Majumdar at Berkeley, which would eventually lead to the formation of Alphabet Energy.



2013

Voyager 1 becomes the first man-made object to exit the solar system and enter interstellar space after being continuously powered by a thermoelectric generator for 36 years.

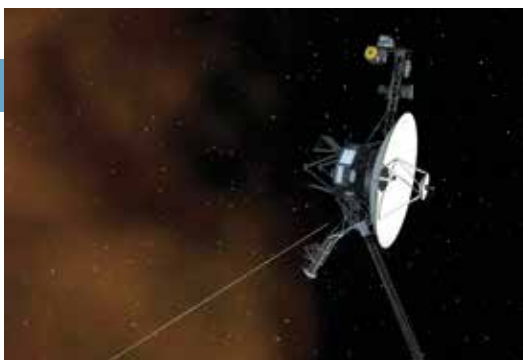

Making unmanned flight safe

RESPONSIBLE ROBOTICS AIMS TO INCREASE DRONE OPERATOR ACCOUNTABILITY

TEXT BY DANIEL MCGLYNN • PHOTO BY NOAH BERGER • GRAPHICS COURTESY RESPONSIBLE ROBOTICS

This spring, the Federal Aviation Administration (FAA) announced that registered unmanned aircraft operators now outnumber licensed manned aircraft pilots.

Raja Sengupta, professor of civil and environmental engineering and co-founder of the startup company Responsible Robotics, heads a team spun out of the Cal Unmanned Aviation Lab that is creating new technologies that enable drone operators to easily comply with emerging regulations.

Sengupta draws parallels between the current drone regulatory environment and the early days of manned aviation, when stunt pilots and entertainers known as barnstormers flew overhead freely until business leaders convinced the federal government to regulate air travel. Today, a new generation of entrepreneurs sees opportunity in the sky.

To foster the safe development of a new industry, drone manufacturers, enthusiasts and regulators are trying to strike the right balance between access and accountability. Responsible Robotics has launched several products to meet that need.

“NO SYSTEMS USED TO IDENTIFY REGULAR AIRCRAFT TODAY ARE SUITABLE FOR DRONES. THAT’S WHY WE MOVED TO THIS VERY CHEAP, LOW-POWER, LOW-WEIGHT SOLUTION, ANTICIPATING THAT SOON THE FAA WILL REQUIRE THAT DRONES HAVE THEIR OWN IDENTIFICATION SYSTEM.”

— AISLAN FOINA | POSTDOCTORAL RESEARCHER AND CO-FOUNDER OF RESPONSIBLE ROBOTICS

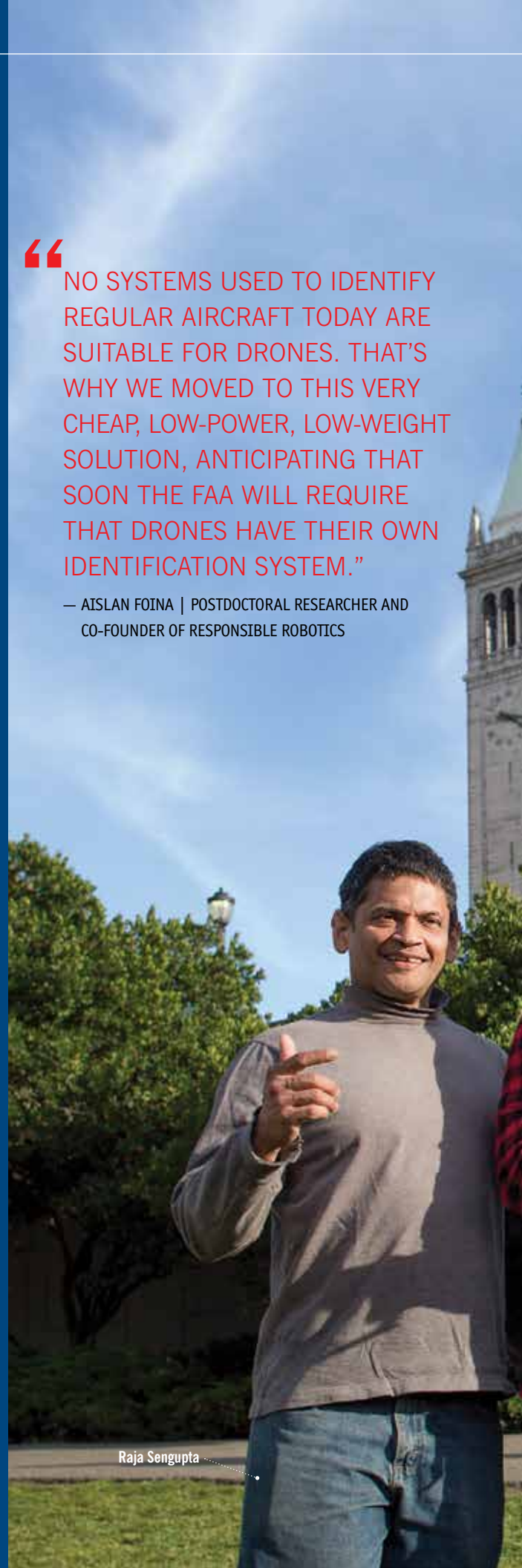

Raja Sengupta

LIGHTCENSE

Designed as a kind of license plate for drones, LightCense creates a signature for each aircraft with coded flashing LEDs embedded on a drone's belly. Smartphone users can record the light pattern to call up identifying details via mobile app. The array doubles as a radio transmitter for long-range identification, and sensors store telemetry data to serve as a "black box" in case of a crash.

TRANSPONDER A Bluetooth transmitter communicates the drone's ID code, permitting automated detection for systems equipped with linked receivers.

SENSORS Simple sensors capture and log flight telemetry data.

BATTERY The rechargeable battery keeps the system transmitting even after a crash, potentially aiding the recovery of a downed drone.

LED ARRAY Bright LEDs blink a coded pattern to visually identify the aircraft, visible from 300 feet, even in daytime.

IFLYLO



The FAA's new unmanned aviation regulations require that drone pilots maintain a flight log, which is where the iFlyLo app comes in. At takeoff, operators open the app and track important flight data, like location and air time. Drone operators and observers on the ground can use the app to identify nearby unmanned aircraft, share information and report accidents.

Aislan Foina

CONTROL YOUR SPACE

The FAA controls all of the nation's airspace above 500 feet. But the rules and best practices for what happens below that ceiling — the prime space for unmanned aircraft — is less clearly defined. The desktop, map-based application Control Your Space allows drone operators to keep tabs on local and national regulations in a specified flight area as well as privacy restrictions on a piece of property. The interface lets drone operators develop flight plans based on permissions and access. As the name implies, Control Your Space also lets homeowners decide to open or close the airspace above their homes, and even charge for access.

2010+

Rachel Gerver (Ph.D.'14 BioE), one of the first students in Berkeley's development engineering program, is now a Biodesign Innovation Fellow at Stanford University. In 2014, she traveled to Kenya with a Development Impact Explore grant to test technology for HIV monitoring and infant diagnosis.

Han Jin (M.Eng.'12 IEOR), founder and CEO of Lucid VR, developed the first stereoscopic camera that records high-definition footage from 180 degrees. LucidCam received the 2015 Technology Lumiere Award from the Advanced Imaging Society, the Ascend Award for best new startup at the Sierra Ventures CXO Summit and the 2015 Innovation for the Future Award from Beijing University and Hanhai Investment.

Connor Landgraf (B.S.'13, M.Eng.'14 BioE), founder and CEO of Eko Devices — known for the smart stethoscope Landgraf began developing as an undergraduate in bioengineering professor Amy Herr's capstone course — received the 2016 Mark Bingham Award for Excellence in Achievement, one of Berkeley's highest honors for alumni.

Anthony Sutardja (B.S.'14, M.Eng.'15 EECS) is the co-founder and CTO of Dray Technologies, Inc., a startup launched last May that allows freight carriers to access a consolidated system for booking loads and managing bill of lading forms and fund transfers from a mobile application. Dray Technologies, now operating out of Berkeley's SkyDeck accelerator, won the eBay Award at the 2015 Kairos Global Summit.

2000+

Johann Aakre (M.S.'04 CEE) was named outstanding young engineer of 2015 by the Structural Engineering Association of Illinois, awarded to those age 35 or younger. Aakre, a senior structural engineer at Howard, Needles, Tammen & Bergendoff Corporation, has worked for more than 10 years on projects such as Chicago's Navy Pier Pedestrian Bridge and the Stan Musial Veterans Memorial Bridge in St. Louis.



Elena Proakis Ellis (M.S.'01 CEE) was appointed as the city engineer for the administration and engineering divisions of public works in Melrose, Massachusetts. She is responsible for the overall management of the division, operations and capital project budgeting, support to the planning and zoning boards and more. Previously, Ellis served as an engineer for the water and sewer division of Concord for eight years, until she returned to consulting with CDM Smith, the company she worked for post-graduation.

David Fanfan (M.S.'01 CEE) earned an M.B.A. at Hult International Business School and traveled to Asia (among other adventures), before settling in New York. A former International House resident, he credits I-House as "a motivator for me to become a better global citizen."

Arlo Faria (B.S.'04 EECS, Ph.D.'14 CS) is a co-founder of ReMeeting, a mobile application and cloud service that enables users to record and search through spoken conversations. As a graduate student, Faria

researched algorithms and systems for speech and audio signal processing and pattern recognition at the International Computer Science Institute.

David Kang (M.S.'04 CEE) was named vice chancellor for infrastructure and safety at the University of Colorado, Boulder. Previously, as the White House director of project management, he developed the vision for more strategic and sustainable facilities at the White House.

Tal Lavian (Ph.D.'06 CS) won Best Presentation Award for the paper "R&D Models for Advanced Development and Corporate Research" at the IEEE/ICE International Technology Management Conference in Belfast, Ireland in June, along with professor **Ikhlaq Sidhu** and associate instructor **Victoria Howell**.

Alexandra Meliou (M.S.'05, Ph.D.'09 CS) received the National Science Foundation's CAREER award for her work on improving data quality and data-driven processes through reverse data management. "Data is critical in almost every aspect of society, including healthcare,

education, economy and science," she says. "However, it is often misused because its validity and origin are unclear, and mistakes easily propagate."

Ryan Panchadsaram (B.S.'07 IEOR) is the deputy chief technology officer at the White House, promoting more effective use of technology by the federal government. After graduating from Berkeley, he worked for Microsoft and co-founded Pipette, a healthcare startup that was later acquired by Ginger.io. Named a Presidential Innovation Fellow, he gave a TEDMED talk in 2013 about information access for patients.

Anthony Papavasiliou (M.S.'07, Ph.D.'11 IEOR) won the 2015 Best Publication Award from INFORMS (a professional society for operations research, management science and analytics), for the article, "Multi-Area Stochastic Unit Commitment for High Wind Penetration in a Transmission Constrained Network," along with IEOR professor **Shmuel Oren**.

Gordon Rios (M.S.'02 IEOR) earned an M.B.A. at Haas in 1992 and was named Pandora's first official data

Build Change founder addresses CEE Academy Class of 2015

Elizabeth Hausler Strand (M.S.'98, Ph.D.'02 CEE), founder and CEO of Build Change, an international nonprofit that constructs earthquake-resistant houses and schools in developing countries, returned to campus last fall to deliver the 2015 Civil and Environmental Engineering (CEE) Distinguished Lecture.

In her lecture, supported also by the Minner Program in Engineering Ethics, Hausler Strand described how her career studying earthquakes and structural issues led to a Ph.D. from Berkeley and a Fulbright Fellowship at the Indian Institute of Technology in Mumbai.

During her time in India, a devastating earthquake hit Gujarat, killing over 20,000 people and destroying over 400,000 homes unequipped to withstand such seismic force. To prevent future destruction, Hausler Strand launched Build Change in 2004.

"When I started Build Change, it was an engineering challenge, but also a social justice issue, because I think everyone deserves the right to a safe house, regardless of their income," Hausler Strand said in her presentation. "Now it's 11 years later, and almost a quarter of a million people are living in safer buildings because of our work."

At the event, the CEE Academy of Distinguished Alumni inducted civil engineers **Eleanor Allen** (M.S.'97), **Glenn Bell** (M.S.'75), **Reginald DesRoches** (B.S.'90 ME, M.S.'92 CE, Ph.D.'97), **Uri Eliahu** (B.S.'81), **Marwan Nader** (M.S.'88, Ph.D.'92), **Denny Parker** (B.S.'65, M.S.'66, Ph.D.'70), **Yusef Rashid** (B.S.'60, M.S.'62, Ph.D.'65) and **Larry Russell** (B.S.'70, M.S.'71, Ph.D.'76). **Egor Popov** (B.S.'33) and **Barney Vallerga** (B.S.'43, M.S.'48) were inducted in memoriam.

STORY BY DENISE BUI • PHOTO BY NOAH BERGER



In October, **Charles Shank** (B.S.'65, M.S.'66, Ph.D.'69 EECS) received the Enrico Fermi Award from President Barack Obama at the White House. Sharing the award with UCLA physicist Claudio Pellegrini, Shank was lauded for contributions to ultrafast science and energy research. Shank worked at AT&T Bell Laboratories for 20 years before returning to Berkeley in 1989 to become the fifth director of Berkeley Lab, a post he held until 2004. He continued to teach science courses until 2011.

OFFICIAL WHITE HOUSE PHOTO BY PETE SOUZA

scientist in 2011. Rios is now the principal scientist on the playlist team at Pandora Media, working on machine learning-based music recommendation systems. He is also the CTO of zvents.com, recently acquired by StubHub/eBay.

Fang Yu (M.S.'02, Ph.D.'06 CS) is co-founder and CTO of DataVisor, a company specializing in data science, security, analytics and infrastructure. The company has applied for a patent on their security analytics engine, designed to protect online communities from potential third-party threats hidden in the sites. Yu works with fellow Berkeley alumni **Julian Wong** (B.S.'02 EECS) and **Ling Huang** (Ph.D.'07 CS).

1990+

Eve Andersson (M.S.'98 ME) manages the accessibility engineering group at Google, with a passion to help people with disabilities to "be able to work at whatever they want, study what they like, travel wherever they wish, feel free and empowered,"

she told Fox News. Andersson founded ArsDigita Corporation and was a senior vice president at Neumont University in Utah and a visiting professor of computer science at Universidad Galileo in Guatemala.

Dipanjan "DJ" Deb (B.S.'91 EECS) is the co-founder and CEO of Francisco Partners, an international private equity firm that provides capital to technology companies. Previously, he served as a principal with the Texas Pacific Group and was the director of semiconductor banking at Robertson, Stephens and Company.

Marie DesJardins (Ph.D.'92 CS) was named associate dean of academic affairs in the College of Engineering and Information Technology at the University of Maryland, Baltimore County (UMBC). She joined the faculty in 2001. In 2015, she was named an American Council on Education Fellow, one of 31 faculty and administrators in the United States. DesJardins was named UMBC's Presidential Teaching Professor (2014–17) and distinguished member of the Association for Computing Machinery. She recently received a National Science Foundation grant to improve computer science education in Maryland.

Ioannis Emiris (M.S.'91, Ph.D.'94 CS) is a professor in the informatics and telecommunications department of the University of Athens. He moved to Greece in 2002, after eight years at the research institute at Inria Sophia-Antipolis, France. He is coordinating a European training and research network on the algorithmic and mathematical foundations of computer-aided design at ARCADES, a European Union-funded research and innovation program.

Dan Garcia (M.S.'95, Ph.D.'00 CS), Berkeley computer science lecturer, was honored by the Level Playing Field Institute as "Tech Diversity Champion" for bringing greater diversity to computer science. His course, CS10, The Beauty and Joy of Computing — which made campus history in 2013 for enrolling more women than men — was profiled in January in the NPR story, "Adding 'Beauty and Joy' to Obama's Push for Computer Science Teaching."

Nirmal Govind (M.S.'99 IEOR), director of streaming science and algorithms at Netflix, works on optimizing streaming quality with

machine-learning models and algorithms. Prior to Netflix, Govind was CTO of Lightning Bolt Solutions and senior operations research engineer and project manager at Intel.

Susan Hubbard (Ph.D.'98 CEE) was promoted from deputy director of science to associate laboratory director for earth and environmental services at Berkeley Lab. She oversees such projects as the microbes-to-biomes initiative. Hubbard was named to the Berkeley CEE Academy of Distinguished Alumni in 2015.

Young Kwak (M.S.'92, Ph.D.'97 CE), associate professor of decision sciences at the George Washington University School of Business, was named editor-in-chief of the American Society of Civil Engineers' *Journal of Management in Engineering* in 2015. Kwak also serves on the editorial boards of IEEE's *Transactions on Engineering Management* and the *International Journal of Project Management*.

Theodore Piepenbrock (M.Eng.'93 CE) is a senior fellow of the International Institute for Strategic Leadership. He has taught at several leading business schools, most notably the London School of Economics, where he was awarded a teaching prize. Piepenbrock met his wife of 19 years, Belgium native Sophie Marnette (Ph.D.'96 French), at I-House; they have an 11-year-old son, Garry.

Tara Weidner (M.Eng.'95 CE), an integrated transportation analysis engineer at the Oregon Department of Transportation, received the Federal Highway Administration's 2015 environmental excellence award in air quality improvement for her work with the Corvallis Area Metropolitan Planning Organization using GreenSTEP, data analysis software that estimates greenhouse gas emissions based on various transportation and lifestyle scenarios. She serves as the agency's lead on greenhouse gas modeling and analysis to meet legislated statewide and urban greenhouse gas reduction targets.

Tzi-Kei Wong (B.S.'97 IEOR) is senior director of product management, developing the marketing analytics and platform strategy, for BrightEdge, a content performance marketing company founded by CEO Jim Yu and CTO **Lemuel Park** (B.S.'00 EECS).

1980+

Gregory L. Fenves (M.S.'80, Ph.D.'84 CE) was named the 29th president of the University of Texas at Austin last spring. Fenves started his career as an assistant professor in the Cockrell School of Engineering at UT Austin from 1984–87, then returned to Berkeley, where he remained on the faculty for more than 20 years and served as CEE chair from 2002–07. In 2008, Fenves returned to Cockrell as dean, and in 2013, he was appointed executive vice president and provost of UT Austin. Fenves is a member of the National Academy of Engineering.

Diane Greene (M.S.'88 EECS) has been named head of enterprise for Google Cloud Platform. Before joining Google, Greene co-founded VMware in 1998 with husband and Stanford professor **Mendel Rosenblum** (M.S.'90, Ph.D.'92 CS), where she served as its first CEO until 2008. She serves on the Google board as the senior vice president for Google's enterprise business. *Business Insider* named Greene first in a list of "most influential women engineers" in 2016. Fellow alum **Tara Bunch** (B.S.'85 ME), vice president of AppleCare, Apple's technical-service and support organization, was named third.

Oliver Günther (M.S.'85, Ph.D.'87 CS) has served as the president of the University of Potsdam in Germany since 2012. Earlier, he was the president of the German Informatics Society, Gesellschaft für Informatik, Germany's leading association of computer scientists, and also as dean of Humboldt's School of Business and Economics in Berlin. His research involves enterprise information systems, IT security and privacy, digital asset management, collaborative software and geographic and environmental information systems.

Grace Kang (B.S.'81, M.Eng.'87 CE), communications director at the Pacific Earthquake Engineering Research Center (PEER), was elected to the College of Fellows of the Structural Engineers Association of California.

Michael Luby (Ph.D.'83 CS), vice president of technology at Qualcomm, was named a 2015 Association for Computing Machinery Fellow for his contributions to coding theory, cryptography, parallel algorithms and



Jacobs



Tikka



Desai



Discher

ALUMNI INDUCTED INTO NATIONAL ACADEMIES

The National Academy of Engineering (NAE) named **Paul Jacobs** (B.S.'84, M.S.'86, Ph.D.'89 EECS) and **Kirsi Tikka** (M.S.'84, Ph.D.'89 Naval Architecture and Offshore Eng.) members of the class of 2016. Jacobs, executive chairman of Qualcomm Inc., was recognized for leadership in the design and development of wireless products and services. Tikka, president and COO of ABS Europe Division, was recognized for contributions to internationally recognized standards for ship structural design, construction and maritime safety.

The National Academy of Medicine (NAM) has also named new members in 2016 for contributions to the advancement of the medical sciences. **Tejal Desai** (Ph.D.'98 BioE) is a professor and chair of bioengineering and therapeutic sciences at UCSF and **Dennis Discher** (Ph.D.'93 BioE) is professor of chemical and biomolecular engineering, bioengineering and mechanical engineering and applied mechanics at the University of Pennsylvania.

PHOTOS COURTESY: QUALCOMM (JACOBS), ABS (TIKKA), TEJAL DESAI/UCSF (DESAI), UPENN (DISCHER)

de-randomization. Luby co-founded Digital Fountain and led the team that invented Tornado and Luby Transform codes.

Richard Morales (M.S.'86 CE) is the director of the Georgia Institute of Technology's 16th annual Exploring Engineering Academy, a summer camp for high school students. For 15 years, Morales has served as committee chairman, expanding the academy from 10 students to a record high of 75. With the support

of **Gary May** (M.S.'88, Ph.D.'91 EECS), Georgia Tech's dean of engineering, the academy aims to expand to serve 100 engineering-bound students.

1970+

Donald L. Bix (B.S.'74 Eng. Physics) was named the 15th president of Plymouth State University. Prior to his appointment, he served as vice

chancellor and president of research for the University of Houston System, and more recently as chancellor and professor at the Behrend College in Pennsylvania. "I'm excited about what can be accomplished when we bring education and business together in innovative ways," he says. "The synergy is incredibly powerful and the opportunities created are transformative — for ourselves, our students and our community."

Joseph Decuir (B.S.'72, M.S.'73 ME) has chaired the IEEE Global Humanitarian Technology Conference since September 2010. He became an IEEE fellow for his contributions to video gaming at Atari and Amiga. He has also contributed to such familiar engineering standards as V-series modems, USB and Bluetooth. Decuir returned to campus last April to address engineering students about career management.

Ronald Ketchum (B.S.'75 EECS) is the founder of Ketchum Consulting Services, a company that develops and delivers training in hydro-electric generator equipment. Earlier, Ketchum worked as an electrical engineer for the U.S. Bureau of Reclamation and then spent a decade as chief operations engineer at Hoover Dam before starting his own firm. Looking back on his long career, he advises today's students that perseverance is its own reward: "Faltering is not failing; be forgiving to yourself, but don't forsake your goal."

1940+

Nicholas George (B.S.'49 Eng. Physics) was honored for his lifetime dedication to the Institute of Optics at the University of Rochester with the creation of the Nicholas George Endowed Professorship in Optics. This professorship was established by a gift from Milton Chang, one of George's former students at CalTech, with a commitment from Joseph Goodman, professor emeritus at Stanford University. In the university's announcement of the professorship, Provost Robert Clark said of George, "He pioneered basic research in holography and was the first to develop a theory for the space and wavelength dependence of speckle — a theory applied to remote sensing of satellites and space debris."



The Backup Generator

Gleb Budman (B.S.'95 ME) is the CEO and co-founder of Backblaze, a cloud backup company that offers unlimited storage for a fee of \$5 per month — a price that hasn't changed since the company's inception.

To reduce costs, they produced custom-built servers that enabled Backblaze to stand out in both software and hardware development. Three clicks and Backblaze automatically finds, encrypts and saves all of a user's files, regardless of size or type, to an off-site location.

Budman, who holds five patents on security, squelched the doubt over unlimited storage by posting the server's proprietary design specs in 2009. Because of the innovative design, Backblaze stores 150 petabytes, more data than its leading competitors.

Five years into the company, Budman and his co-founders agreed to seek funding to accelerate growth — but only with investors who wouldn't be making hiring and firing decisions. They teamed up with TMT Investments, which offered \$5 million. Backblaze has since grown to nearly 40 employees.

Last December, one of the original co-founders, Nilay Patel, who graduated with a B.A. in computer science from Berkeley in 2002, returned to Backblaze as the vice president of sales.

The company most recently launched Backblaze B2 Cloud Storage, a competitor with a quarter cost of the service offered by Amazon, Google and Microsoft.

"It's definitely a David vs. Goliath situation," Budman says, but he's confident Backblaze will prevail with its innovative technology and its culture of being focused, efficient and creative.

STORY BY AMY MARCOTT • PHOTO KARL NIELSEN

MORE > An expanded version of this story appeared in *BerkeleyHaas* magazine, fall 2015.

Hollis Bascom (B.S.'45 ME) died in October at age 91. He served in the U.S. Navy during World War II. In 1962, he founded the ORCON Corporation, producing lightweight, non-woven reinforced material fabrics for the aerospace industry. He retired in 2014, after more than 50 years at the company. He held patents in insulation film and carpet-seaming products, used on the Mars Reconnaissance Orbiter and the International Space Station. He also served as the first president of Valley Care Hospital in Livermore, California.

Abraham Bers (B.S.'53 EECS) died in September at age 85. He served as principal investigator in MIT's Research Laboratory of Electronics and the Plasma Science and Fusion Center, where he taught plasma physics and authored the textbook *Plasma Physics and Fusion Plasma Electrodynamics*. He held numerous patents and was an IEEE fellow, member of the American Physical Society and affiliate of Fusion Power Associates.

Robert F. Carlson (B.S.'43 ME) died in November at age 93. He served as a skipper in the Navy in World War II and returned to earn an M.B.A from Harvard. He was the administrative director of the Harvard Observatory in Colorado for five years before co-founding and serving as CEO of Channel Technologies. He was also an active member of the Santa Barbara Club and Rotary Club.

Robert Fenn (B.S.'63 EECS) died in January at age 82. He worked at the Hawaiian Electric Company and General Electric, and was an active member of the Cal Alumni Association.

Ruth Louise Hinkins (M.S.'94 CS) died last April at age 79. A Wisconsin native, she received her B.S. and M.S. in mathematics from the University of Wisconsin, Madison. She taught at Eau Claire State College before moving to California, where she worked for Lawrence Berkeley National Laboratory. She earned her M.S. in computer science from

Berkeley at age 58, and was passionate about solving challenging mathematical problems through programming.

Hormozdyar "Tom" Keyani (B.S.'69 EECS) died in September at age 71. As the head photographer for the Blue and Gold yearbook in 1969, he

documented many dramatic moments of Berkeley protests. His two daughters also attended Berkeley: Jennifer Keyani (Ph.D.'07 Chemistry) and **Maria Keyani** (B.S.'04, M.S.'06 CEE).

Frank D. Masch Jr. (Ph.D.'62 CE) died last April at age 82. He earned his bachelor's and master's degrees at the University of Texas at Austin, and later joined UT's civil engineering faculty and directed the Hydraulic Research Laboratory. Earlier, he was president of Water Resource Engineers and vice president at Systems Associates; he pioneered models for the simulation of hydrodynamics and water quality systems. He received the Eminent Texas Hydrologist Award and John Hawley Award and was named Science Faculty Fellow by the National Science Foundation.

Clyde N. Moore Jr. (B.S.'40 CE) died in May at age 97. According to his family, he always spoke fondly of his years at Cal, including collecting water quality samples on San Francisco Bay and his job serving food at a girls' rooming house. He worked nearly 40 years for the Long Beach Water Department, serving as general manager and chief engineer, among other positions.

Gerald Wieczorek (B.S.'71, M.S.'72, M.Eng.'74, Ph.D.'78 CE) died last February at age 65. He worked as a geotechnical engineer for the U.S. Geological Survey offices in Menlo Park, California and in Reston, Virginia for a total of 34 years.



David Dornfeld, faculty director of the Jacobs Institute for Design Innovation, the former chair of mechanical engineering and a worldwide expert in smart and sustainable manufacturing, died in March. He was 66. Dornfeld held the Will C. Hall Family Professorship and led Berkeley's Laboratory for Manufacturing and Sustainability. He was a member of the National Academy of Engineering, a fellow of the American Society of Mechanical Engineers and received many other honors and awards during his tenure at Berkeley, which began in 1977. As a department chair, Dornfeld expanded industrial relationships and led Berkeley's participation in the Advanced Manufacturing Partnership, a national initiative to encourage investment in emerging technologies for the enhancement of U.S. manufacturing competitiveness. He mentored countless students and was an advocate for experiential and entrepreneurial engineering education.

NOAH BERGER PHOTO

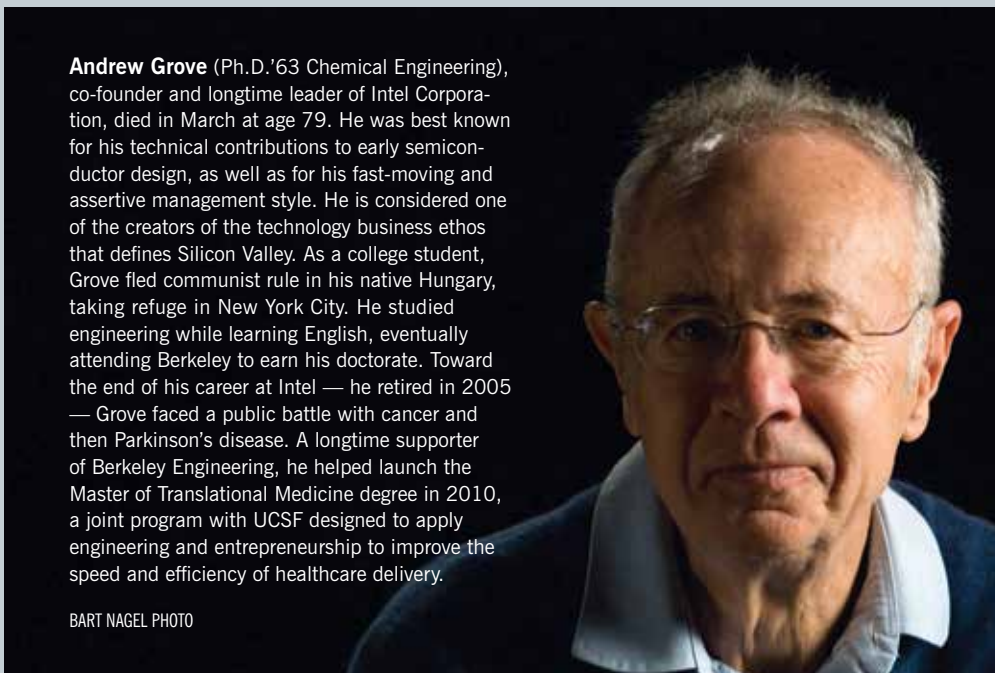

Andrew Grove (Ph.D.'63 Chemical Engineering), co-founder and longtime leader of Intel Corporation, died in March at age 79. He was best known for his technical contributions to early semiconductor design, as well as for his fast-moving and assertive management style. He is considered one of the creators of the technology business ethos that defines Silicon Valley. As a college student, Grove fled communist rule in his native Hungary, taking refuge in New York City. He studied engineering while learning English, eventually attending Berkeley to earn his doctorate. Toward the end of his career at Intel — he retired in 2005 — Grove faced a public battle with cancer and then Parkinson's disease. A longtime supporter of Berkeley Engineering, he helped launch the Master of Translational Medicine degree in 2010, a joint program with UCSF designed to apply engineering and entrepreneurship to improve the speed and efficiency of healthcare delivery.

BART NAGEL PHOTO



Members of the Class of 1951



Jeanette and Don Lee

Photos courtesy Lee family

New job, retirement, graduations, publications, travel — let us know.

Send your news to the editors by email to berkeleyengineer@berkeley.edu, or mail to Berkeley Engineer editors, Berkeley Engineering, 312 McLaughlin Hall #1704, Berkeley CA 94720-1704.

First name	Last name
Degree & year	Department
Email	
Mailing address	
City, state	Zip code

YOUR CLASS NOTE (please print legibly):

Living the dream

The success of Don Lee (B.S.'51 CE) has been fueled in large part by his education at Berkeley Engineering. It's one of the reasons he has remained a steadfast donor over the course of his life.

"I feel that I got a lot out of Cal," he says. "It prepared me so well, so this is payback."

Through the endowed Don Y.F. and Jeanette Lee Family Scholarship fund, other aspiring engineers will be able to pursue dreams of their own. Lee used a gift of real estate as well as gifts from his IRA account to create the scholarship fund. Giving the real estate to Berkeley frees him up from the effort of selling the property himself, and IRA gifts are easier than ever now that the IRA Charitable Rollover is a permanent part of the tax code.

You, too, can create a legacy gift that benefits the college, yet offers tax and other economic benefits for yourself and your family.

To learn more, contact College Relations at (510) 642-2487 or visit engineering.berkeley.edu/give.

Connect on social media

Follow what's happening at the college, learn about lectures and events, post your news and join in the conversation. We want to hear from you!



Follow [@Cal_Engineer](https://twitter.com/Cal_Engineer)



Like facebook.com/BerkeleyEngineering



Subscribe youtube.com/BerkeleyEngineering



Join Berkeley Engineering Alumni at LinkedIn.com

Berkeley**ENGINEER**
University of California, Berkeley
College of Engineering
Office of Marketing & Communications
Berkeley, CA 94720-1704

NONPROFIT ORG.
U.S. POSTAGE
P A I D
UNIVERSITY OF CALIFORNIA,
BERKELEY

Where dreams take flight

Help students get ideas and inventions
off the ground with your gift to the
Berkeley Engineering Fund.

Learn more and make your gift at:
engineering.berkeley.edu/give.

